



Tractors

AXION

960 950 940 930 920



Tougher, inside and out.
The AXION 900.





TERRA TRAC Concept	4
Features	5
Overview	
TERRA TRAC	6
AXION Competitive Comparisons	8
Suspension	10
CLAAS Power System + Engine	12
CMATIC	14
Stability	16
Linkage	18
Cab Comfort + CEBIS	20
CEBIS	22
CMOTION	24
Maintenance	26
Specifications	28
CLAAS Service + Parts	29



More innovation:
more details here.

AXION 900 Series

The advantages of TERRA TRAC.



Get on the right TRAC.

The AXION 900 has always been ready to take on those really big challenges: with powerful engines delivering up to 445 hp, continuously variable CMATIC, driving comfort and enormous tractive power. Now the AXION 900 TERRA TRAC has arrived – the world's first half-track tractor with full suspension and it's ready to tackle the toughest row crop applications in North America.

Make the most of its strengths.

- Operate the tractor intuitively via the 12" CEBIS touchscreen
- Use brake-assisted steering to achieve an ideal turning radius - a feature that comes standard
- Improve ground clearance and manually adjust the drawbar height directly within CEBIS for easy implement hook-ups

15% more traction.

- Larger implements
- Less slippage
- Lower working speed means less wear
- Lower fuel consumption

25% larger footprint, 25% less ground pressure.

- Protects soil
- Fewer tracks reduce tillage costs
- Saves costs of subsequent tillage
- Improves yield at headlands

Added comfort.

- Fully suspended TERRA TRAC system
- Standard four-point cab suspension
- Strategically placed operator seat



CLAAS POWER SYSTEMS.

- Full engine power available at all forward speeds and for all applications
- Low-speed concept: maximum output, maximum torque and maximum top speed at a much lower engine speed reduce operating costs significantly
- Exceptional CMATIC transmission control: dynamic, smooth and fuel-efficient
- Up to 95% of maximum engine output available to the PTO in 1,000 ECO mode at 1,600 engine rpm
- Up to 58 gpm hydraulic capacity and eight electronic spool valves

Comfort and convenience.

- CEBIS version with unique operation thanks to CMOTION multifunction control lever, 12" CEBIS display with touchscreen, electronic spool valves, CSM headland management, field and implement management
- 4-point cab suspension comes standard
- GPS PILOT with S10 and S7 touchscreen terminal
- TIM (Tractor Implement Management) when the AXION is combined with the QUADRANT or CARGOS

Reasons to love TERRA TRAC.

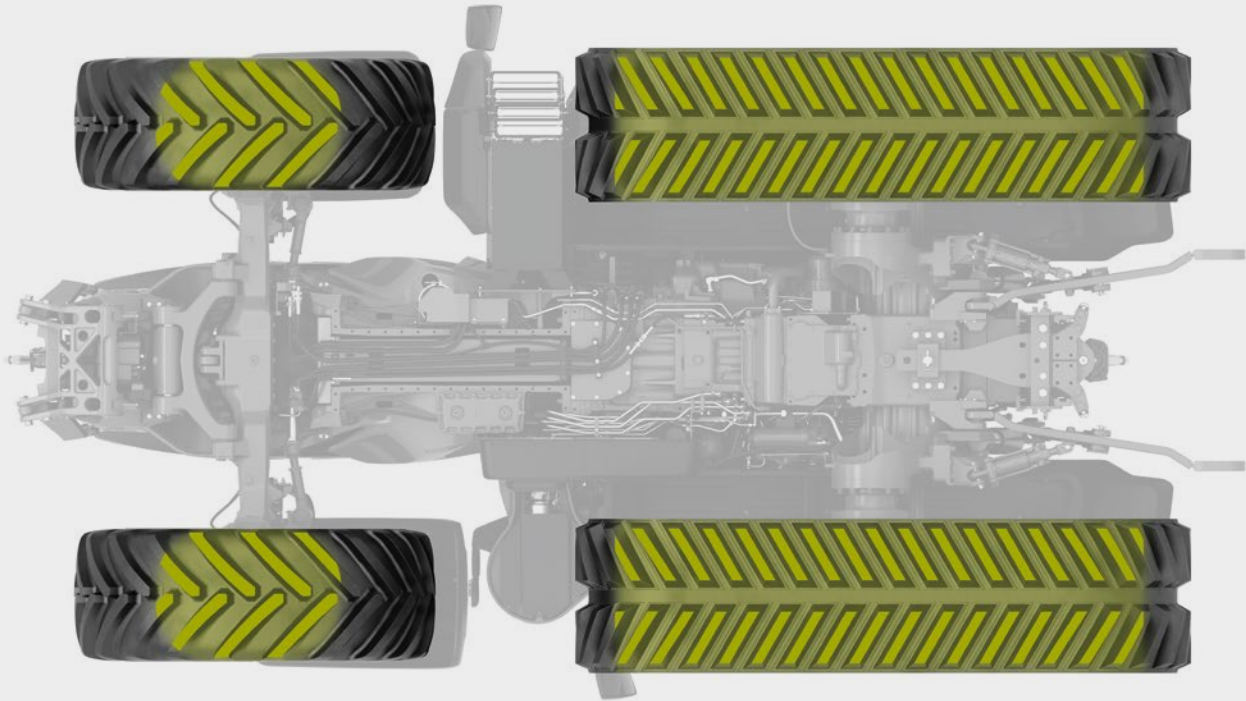

Row crop ready.

The TERRA TRAC drive concept with its patented geometry combines reliable, durable components with sophisticated technology.

Friction-locked drive.

The drive wheel is designed to maximize the friction between the wheel and the track by utilizing almost the entire width of the track and using rubber cleats to provide a friction lock, even in harsh and difficult pulling conditions.

Self-cleaning drive wheel and guide wheel.

Spoked wheels fitted with individual rubber pads maintain close contact with the track surface. Since they are self-cleaning, they reliably transmit the driving power even under extremely muddy conditions.

Wheels with independent suspension.

Independent wheel suspension has distinct advantages on undulating soil surfaces. Maximum traction is achieved by keeping the entire length of the track in closer contact with the soil. And more even distribution of pressure provides even better soil protection.

Customizable to meet your needs:

- 18 inch belts
- 25 inch belts
- 29 inch belts
- 35 inch belts

Two fuel tanks with a combined volume of 227 gallons are mounted above the rear mudguards. These tanks offer the driver unrivaled autonomy by minimizing the need for refueling stops. So instead of wasting valuable time at the pump, they can spend it productively on the field.

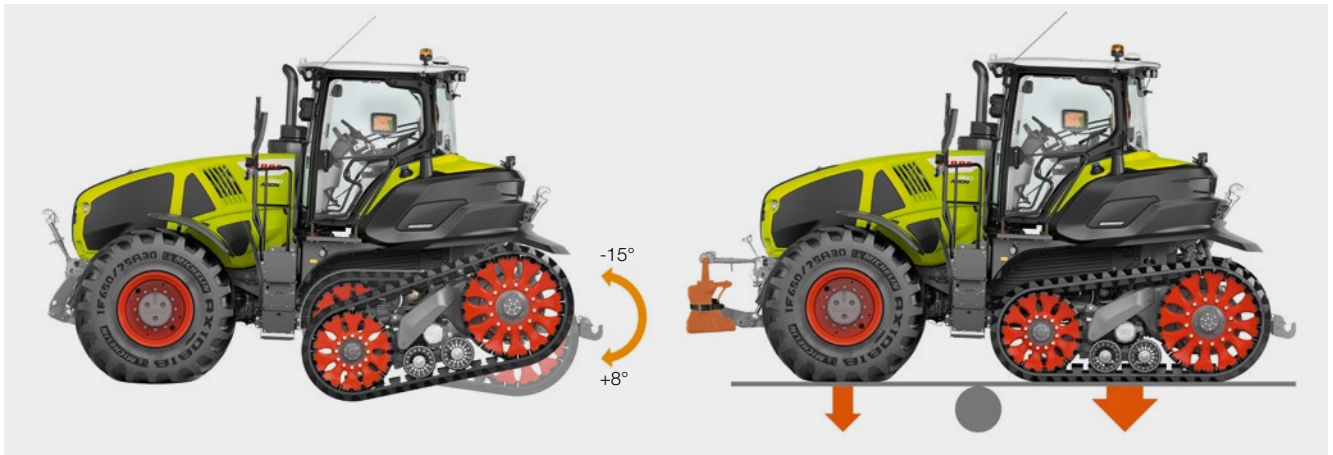

Make the most of the TERRA TRAC concept.

The AXION 900 TERRA TRAC drives like a conventional four-wheel tractor and has front-axle steering. This allows drivers to operate the machine intuitively without having to relearn, and to take full advantage of all the benefits of the half-track concept.

Powerful traction.

The long wheel base and front axle provide effective directional stability. Both track assemblies deliver their full traction potential at all times, even under varying soil conditions.

Steady pressure.

The vehicle's weight distribution and the implement's drawbar load have no effect on the behavior of the TERRA TRAC units. Hydraulic cylinders in the tracks continuously work together to either smile or frown in order to keep in constant contact with the ground.

Stamina abundance.

These self-cleaning tracks are friction drive with 33% less bends than competitive models, decreasing heat build-up, allowing the operator to work longer durations, and improving the lifespan of your tracks.

Brake assisted steering.

Standard on every AXION TERRA TRAC tractor, brake assisted steering is integrated into the existing machine brakes for a seamless experience. User adjustabilities on the fly range from completely off to high aggressivity.



Discover how TERRA TRAC adds value to your operation.

AXION 900 Series.

Know it by the numbers.

Efficiency.

CLAAS tractors stands strong, delivering engineered performance that saves fuel, time, labor, and provides you with quality outputs and brighter business solutions.

Save more fuel.

Fuel efficiency is a vital part of our commitment to your farming operation. That's why we challenge ourselves to find new and improved ways to make the AXION tractor the most fuel-efficient in agriculture.

The superior fuel efficiency of the AXION can be attributed to its ability to better transfer the engine's torque and power through the 4-range continuously variable CMATIC transmission. This technology coupled with a strategically designed fuel map leads to savings while still achieving a high level of performance.

AXION 900 Series saves up to **19.5%** in fuel.

	% MORE FUEL USED
Case IH	19.5%*
John Deere	17%**
Fendt	8%*

* Derived from internal studies, 2021
** Derived from internal studies, 2020

CMATIC 4-RANGE TRANSMISSION

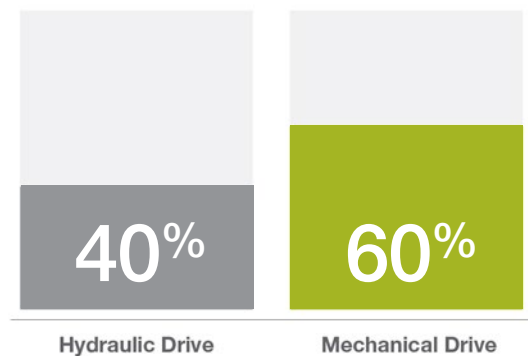

Increase track lifespan.

The TERRA TRAC concept encompasses a friction drive design, with 33% less bending than a positive drive track design. Heat build-up can contribute to lowering the life of tracks and add expensive costs to general tractor maintenance.



up to
20% less
heat build-up

105.5°F*

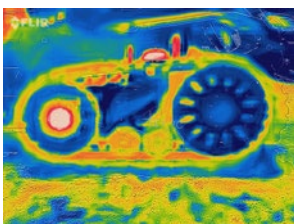

AXION 930 TT

129°F*



Case IH Magnum Rowtrac 340

front + back

115°F*

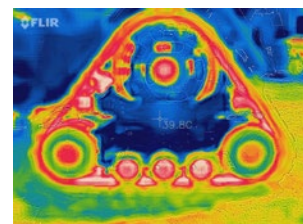

John Deere 8RX 370

* Derived from internal studies, 2021

Productivity.

The AXION transfers more power to the ground, producing less slippage and greater overall productivity.

AXION 900 Series works up to **35%** more acres per hour.

ON WHEELS	% MORE ACRES WORKED
Case IH	35%*
Fendt	9%*
ON TRACKS	
John Deere (8RT)	5%*
John Deere (8RX)	14.5%*

* Derived from internal studies, 2021

COMPARE RATED HP
AMONG SIMILAR 2WD TRACKED TRACTORS

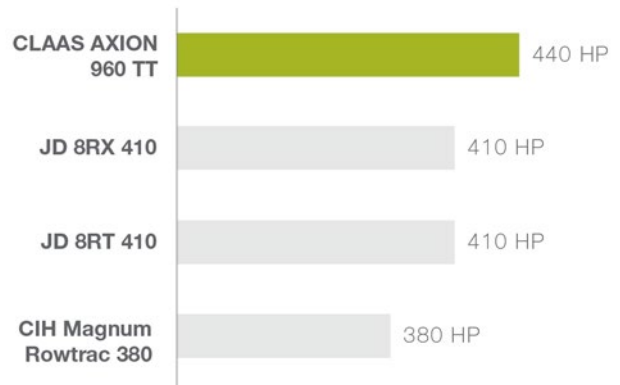

Comfort.

From the strategically positioned operator's seat to a four-point cab suspension that comes standard, the AXION offers a level of comfort that competitive brands can't match.

4-POINT SUSPENSION COMES STANDARD

	STANDARD	OPTIONAL	NONE
CLAAS	✓		
John Deere		✓	
Case IH		✓	
Fendt			✓

* Derived from build options, 2022

Experience exceptional quality.

An accelerometer proves the AXION has exceptional ride quality. The flatter the lines, the less distance movement is being recorded. The thinner the lines, the less force movement is being recorded.

SIDE-TO-SIDE READINGS @ 7 MPH:



* Derived from internal studies, 2021

Protects both driver and machine. The suspension.

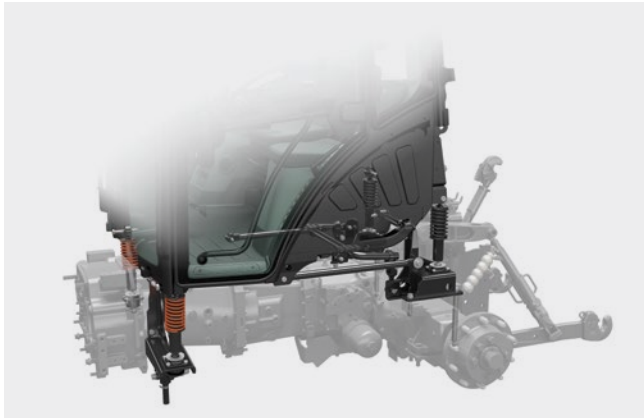

Full 4-point suspension.

Four suspension points mean that the cab is fully isolated from the chassis, preventing impacts and vibration from reaching the driver. Longitudinal and lateral struts join the suspension points and keep the cab stable when turning corners or braking. The entire suspension system is completely maintenance-free.



PROACTIV front axle suspension – complete comfort automatically.

The suspension adjusts to the tractor loading and automatically remains in the central position. Changes in load due to braking and turning maneuvers are also compensated.



Sit better. Work better.

The wide range of seats includes a ventilated premium seat.

- Active seat ventilation makes the seat feel comfortable no matter what the weather
- Suspension automatically adjusts to the driver's weight



Dampen vibrations even more.

The AXION 900 TERRA TRAC provides the same suspension points for the cab, front axle and linkage. The damping effect of the rear tires is replaced by the unparalleled hydraulic suspension of the TERRA TRAC. So you can enjoy the same level of comfort in the field and on the road as the wheeled model.



Switch to activate front axle suspension.

CLAAS POWER SYSTEMS + Engine

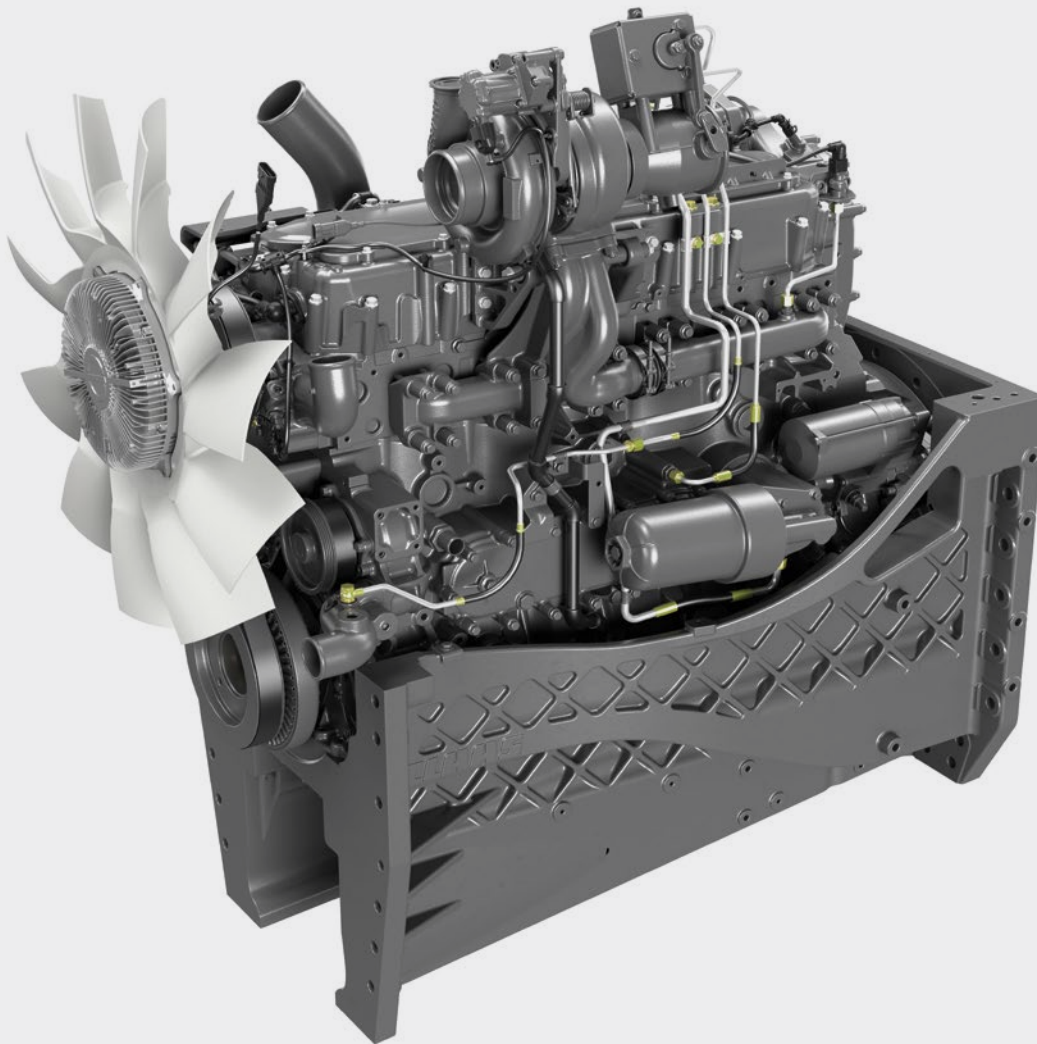

Our drive system: the perfect interplay between optimal components.

Your CLAAS machine is much more than the sum of its individual parts. Top performance is only possible when all the parts are ideally matched and work together optimally.

In CLAAS POWER SYSTEMS (CPS), we have brought together top-quality components to create an intelligent drive system that sets new standards. Full engine output only when you need it. Drives that are suited to the way your machines are used. Fuel-saving technology which quickly pays off.

Pure power.

The AXION 900 is designed for field work as well as transport work. That's why it delivers its full engine output – without a boost – for every type of job. Even heavy tillage at low speeds is no problem. Thanks to CMATIC powertrain management, the AXION 900 employs a low-speed concept: higher output at lower engine speeds and automatic engine speed adjustment reduce operating costs.

A 6-cylinder, 8.7 liter FPT Cursor 9 engine gets to work under the one-piece hood. It is equipped with the latest common rail 4-valve technology, charge-air cooling and a variable geometry turbo (VGT).

Low-speed concept.

Higher output with lower fuel consumption – this was the goal CLAAS engineers wanted to achieve when developing the innovative low-speed concept for CMATIC tractors.

Further benefits include greater convenience and longer working hours on one tank of fuel:

- Constant output range of 1,700 to 1,900 rpm
- Constant torque range of 1,300 to 1,500 rpm
- 95% of max. output available at the 1000 ECO rear PTO
- Reduced engine speed for transport work at 24 to 31 mph (1,400 or 1,600 rpm)
- Two idling speeds (650 and 800 rpm) with automatic adjustment reduce stationary fuel consumption

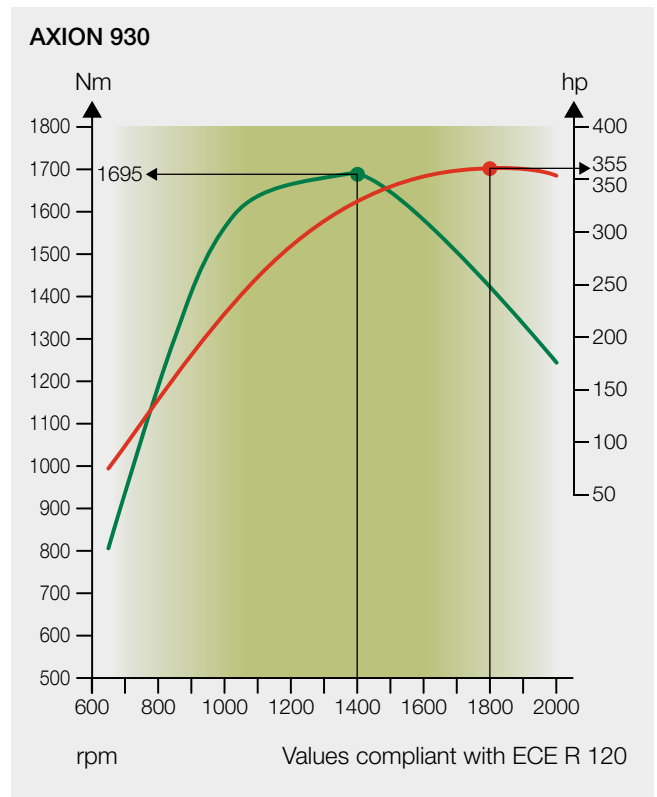

Integrated SCR system.

When designing the AXION 900 series, the components required for exhaust gas aftertreatment were considered from the outset. The diesel oxidation catalytic converter (DOC) is positioned under the hood immediately behind the turbocharger because it needs high exhaust temperatures to produce an optimum reaction. The SCR catalytic converter is an integral part of the exhaust system and is located on the right-hand side of the tractor right behind the A-pillar in the cab, where it does not compromise driver visibility and machine accessibility.

Variable turbo.

The VGT turbo delivers optimum charge-air pressure at any engine speed. It adjusts to load and engine speed, making 70% of maximum torque available even when idling. Optimized combustion therefore means low fuel consumption and maximum performance.

AXION	Torque (Ft Lbs)	Maximum output (hp) ECE R 120
960	1372	445
950	1342	410
940	1305	385
930	1250	355
920	1180	325

CLAAS CMATIC.

Continuously variable and no need to stop.



Efficient and user-friendly.

CMATIC is the name of the continuously variable transmission technology used in CLAAS tractors. In the AXION 900 series a ZF Terramatic transmission provides efficient conversion of engine power. In this split-power, continuously variable transmission, the four mechanical ranges are automatically selected by multidisc clutches. There is no need to shift between ranges manually.

The high mechanical component in the power transmission provides outstanding efficiency and low fuel consumption in every speed range.

Superior transmission control.

Powerful acceleration, smooth deceleration, and a fast response to changes in load: CMATIC powertrain management shows its capabilities in all conditions and for every task. Stay relaxed and focused throughout the working day so you can concentrate on more important things – CMATIC does the rest for you.

Exploiting real potential.

The full power of the transmission can be used at speeds from 0 to 31 mph. The high level of mechanical power transmission also delivers outstanding driving force in reverse. What's more, every gear ratio can be used at every engine speed, giving AXION 900 tractors enormous potential for use all year round.

With engine speeds of 1,600 rpm at a top speed of 31 mph and 1,400 rpm at 24 mph, the AXION 900 also demonstrates its capabilities in transport operations. If the accelerator is not depressed, the transmission is in powered zero mode and maintains its position without creeping or rolling. This means that the tractor can start up safely and easily at steep field entrances or road junctions, even with a full load.



Engine droop setting for “Eco” and “Power”, and the engine speed memory.

Simple, straightforward operation.

The CMATIC transmission has three operating modes: accelerator pedal, drive lever, and manual mode.

In the first two modes, forward speed can be controlled by the accelerator pedal or drive lever. The engine speed and transmission ratio are adjusted automatically – for optimum efficiency and optimized fuel consumption. In manual mode, the driver chooses the engine speed and transmission ratio. Automatic engine and transmission control is disabled.

Tailor-made speed ranges.

With the CMATIC transmission, three speed ranges can be pre-selected in both directions of travel. The active range is displayed in the CEBIS and can be changed while the tractor is in motion using two buttons. The lower the maximum preset value for the range, the more accurately the speed can be controlled.

A cruise control speed can be saved for all the ranges while the tractor is moving by pressing the button on the drive lever. The cruise control speeds can also be pre-set on the CEBIS terminal. CMATIC allows drivers to create their own profiles according to the job at hand. Intelligent CMATIC transmission technology enables you to use the full power of your AXION economically and productively – with maximum operator comfort.

Engine droop at the push of a button.

The engine droop value can be used for quick and easy regulation of the engine speed under full load. The CEBIS terminal clearly displays the engine speed at which the transmission reduces the speed.

When a constant engine speed is activated, i.e. during PTO work, the driver can specify a different droop setting, typically one that matches the engine speed to the required PTO shaft speed.

Two engine droop values can be saved for engine droop in accelerator pedal and drive lever mode. They are retrieved by the quick-access facility using the F buttons. With these values, known as “Eco” and “Power”, the droop can be rapidly adjusted to the task at hand, e.g. when moving from the road to the field. The engine droop for the engine speed memory is defined separately.

Stable and maneuverable.
Immense tractive power.



Real stability.
The true sign of a 400 hp tractor.

CLAAS has drawn on experience gained in developing standard tractors and XERION large tractors delivering 500 hp or more to create a completely new solution for the AXION 900 – for endurance work under extremely challenging conditions. The engine is housed in a strong frame section with an integrated engine oil sump which perfectly absorbs all the forces associated with the front linkage and front axle carrier.

The benefits:

- Maximum stability even when using heavy front-mounted implements
- Optimum access to the entire engine compartment and all maintenance points
- All services securely routed within the frame section



Long wheelbase – compact design

To transfer 400 hp to the ground, the design must be just right. The AXION 900 ticks all the boxes. It has a wheelbase of 124 inches, but its outstanding design makes it maneuverable in the field and easy to drive on the road.

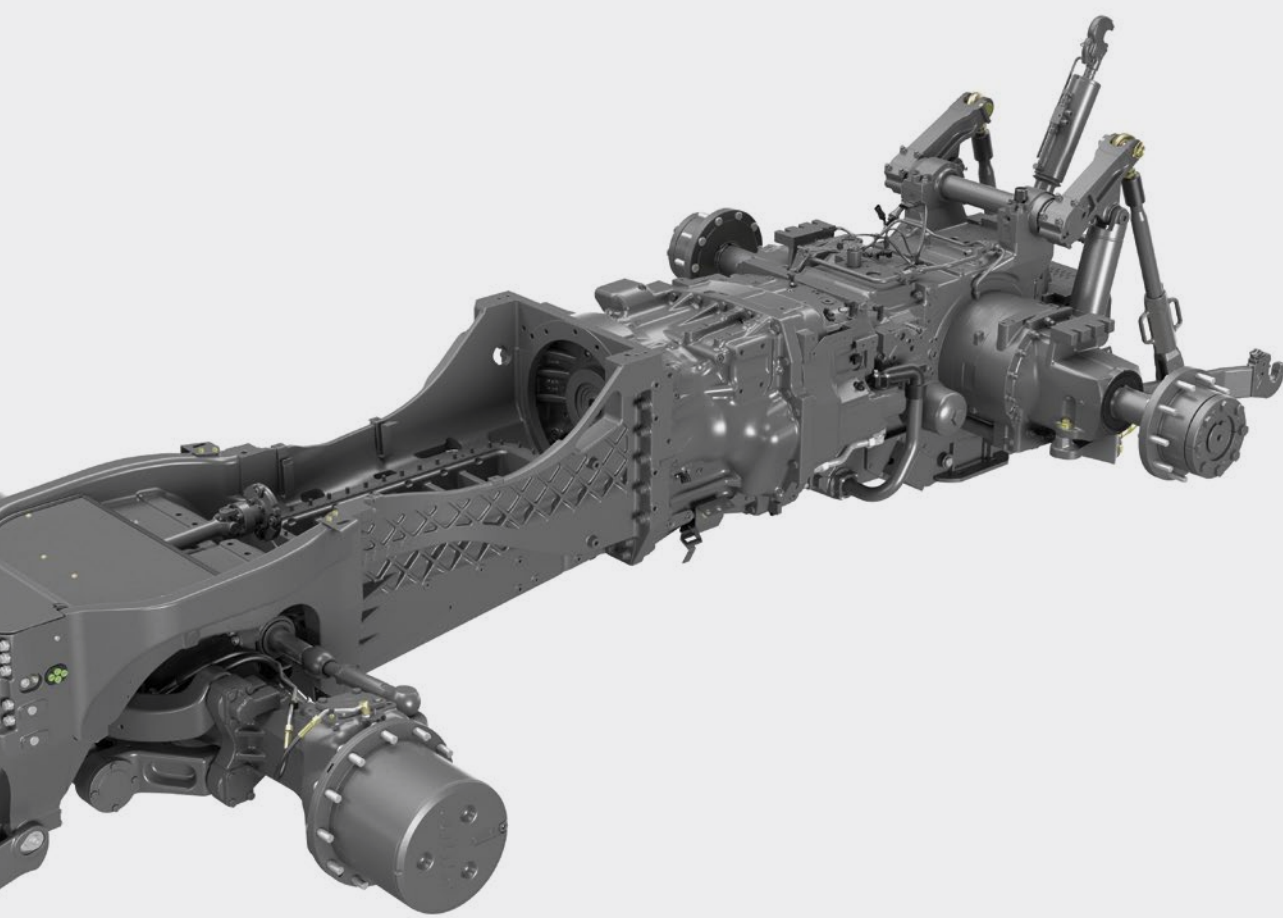

Short overall length:

- Excellent maneuverability
- Short trailer combination on the road
- Great visibility
- Superior guidance of front-mounted implements



Good power to weight ratio:

- Optimizes fuel consumption
- Low ground pressure during tillage
- Dynamic road transport
- 50 : 50 weight distribution front / rear

Lifts any implement.
The rear linkage.



A hitch to suit every need.

A number of holes are provided in the drawbar versions so that the distance between the PTO stub and hitch point can be adjusted. This gives greater flexibility and improves maneuverability.

Direct adjustment.

The convex rear window and swiveling seat provide an excellent view of the implement and unimpeded operation of the rear linkage controls. The conveniently located controls enable the driver to optimize the rear linkage settings while work is in progress.

The rear linkage.

All AXION 900 models have a maximum lifting capacity of 24,000 lbs which enables them to carry the heaviest of implements. The rear linkage configuration can be tailored to individual requirements:

- Cat. IV lower links
- Mechanical or hydraulic top link, Cat. IV
- Swayblocks or automatic stabilizers for both lower links
- Wheel slip control via radar speed
- External controls on both fenders for the rear linkage, PTO and one electronic spool valve.

More versatility.
More applications.



Front linkage.

All AXION 900 models can be factory-fitted with a 6.5 t front linkage for particularly heavy implements. The AXION has a fully integrated front linkage, designed by CLAAS specifically for this power class. The front axle carrier and the special structural component for the engine are designed to absorb any forces generated, meaning no additional supports or rails are required. A 1,000 rpm front PTO is also available. It is effortlessly engaged by pressing a button in the cab. Compact construction has a short distance between front axle and coupling points; with good implement handling and short overall length.



Front linkage with position control.

In the CEBIS version a position control system is optionally available for the front linkage, enabling you to work accurately with front-mounted implements.

The operating position is adjusted with a rotary knob on the armrest, and you can limit the lifting height and set the lifting and lowering speed in the CEBIS. The front linkage can be used in single- or double-acting mode.



External controls for the front linkage and one spool valve.

A clear view cab.

4-pillar concept.

The CLAAS 4-pillar cab offers some distinct advantages:

- Clear view of the full working width of attached implements
- Large-volume cab creates an extremely spacious working environment
- Continuous windscreen

The strategically positioned rear cab pillars give the driver an excellent view of the implement and hitch area. Spacious and quiet, with large windows and full suspension. The AXION 900 cab guarantees maximum comfort throughout long working days.

CEBIS will delight more technologically-minded users who want to enjoy the highest level of comfort. From CSM headland management through implement management to TIM (Tractor Implement Management) – the CEBIS has plenty of functions up its sleeve.

Spool valve prioritization, camera image, ISOBUS implement, control implement, and job management, as well as many other functions – CEBIS meets your every need. All settings can be entered in seconds thanks to touchscreen operation and logical menu navigation, while the armrest with the CMOTION multifunction control lever offers top levels of comfort.





An armrest that sets new standards.

The height and position of the armrest can easily be adjusted to the driver's requirements. Functions that are used less frequently, such as PTO speed preselection and the main switches, are located to the right of the driver's seat. When the driver's seat is rotated, the electronic linkage control system can be operated comfortably with an excellent view of the attached implement. Fine adjustment of the settings can then take place while work is in progress. Two additional buttons enable you to raise and lower the rear linkage manually for easier implement attachment.



Clear, logical layout.

In CEBIS, many functions can be directly controlled using the rotary switches and buttons on the B-pillar:

- A PTO speed selection
- B Controls for electronic rear linkage control system
- C Rear linkage status display
- D Rear linkage settings

CEBIS terminal.



Clear layout and fast operation.

The 12" CEBIS screen uses self-explanatory symbols and color coding to give a clear picture of the settings and operating statuses. Thanks to the CEBIS menu structure and touchscreen, all settings can be entered in just a few steps. A particularly attractive feature is the DIRECT ACCESS function with the machine silhouette. Just tap the relevant area to get straight to the right dialogue window.

An eye-catching 12" screen.

- 1 Machine silhouette for DIRECT ACCESS and status display
- 2 Spool valve status
- 3 Vehicle information
- 4 Top sub-field: performance monitor
- 5 Middle sub-field: function button assignment
- 6 Bottom sub-field: transmission information
- 7 Menu
- 8 DIRECT ACCESS via CEBIS touch button or button on the armrest
- 9 Dialogue-based system for optimum settings



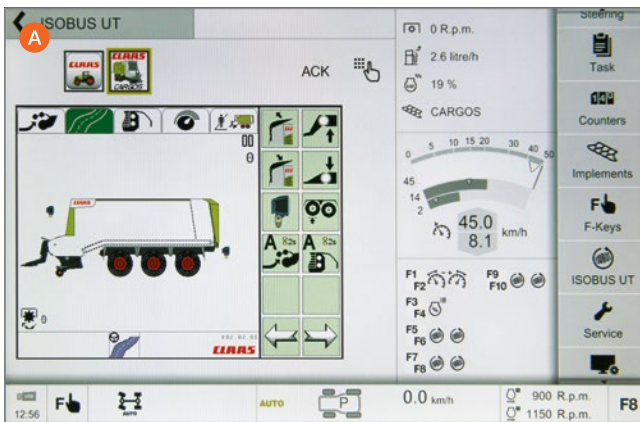

- 1 Navigation in the menu
- 2 Select
- 3 ESC button
- 4 DIRECT ACCESS button

CEBIS – simply better:

- Fast and intuitive navigation using the CEBIS touchscreen
- Rapid access to the sub-menus with the DIRECT ACCESS touch button on the CEBIS or button on the armrest
- Tap the machine silhouette, main field or sub-field
- Navigate using the rotary/push switch and ESC button on the armrest – ideal when driving on rough terrain
- Two different screen layouts available (road travel and field work)
- ISOBUS function
- Specify the user type: limit the scope of CEBIS settings to suit driver experience
- Freely assign the three sub-fields, e.g. for transmission, front and rear linkage, function buttons, headland sequences, camera or performance monitor

As well as screen-based operation with the CEBIS, there is a set of buttons in the armrest. Full CEBIS operation is available using the rotary/push switch and ESC button if uneven ground reduces the accuracy of fingertip operation. The DIRECT ACCESS button takes you straight to the settings for the last used tractor function.

Integrated ISOBUS implement control (A).

- In CEBIS intuitively switch between ISOBUS implements, road travel and field work screen layouts
- Clear view of ISOBUS implements in main field
- Simply connect ISOBUS cable at the front or rear and off you go
- Assign up to ten ISOBUS functions to CMOTION function buttons for direct operation

Camera image display function (B).

- 1 Display up to two camera images in the sub-field
- 2 Toggle between machine silhouette, Camera 1 and Camera 2 in the main field

CMOTION multifunction control lever.



At the push of a button.

- 1 Start up/change direction
- 2 Rear linkage
- 3 GPS PILOT activation
- 4 CSM headland management
- 5 Function buttons F7 / F8 / F9 / F10
- 6 Activate cruise control
- 7 Function buttons F1 / F2
- 8 Function buttons F5 / F6

The free assignment option for the ten function buttons on the CMOTION means that there's no longer any need to reposition your hands while you work. All implement-specific ISOBUS functions are easily controlled using the CMOTION:

- ISOBUS functions
- Event counter on/off
- Spool valves

Rear linkage functions on the CMOTION:

- Lower to preset working position
- Raise to the preset lift height position
- Manual activation: lift and lower at two speeds (slow/fast)
- Quick implement entry

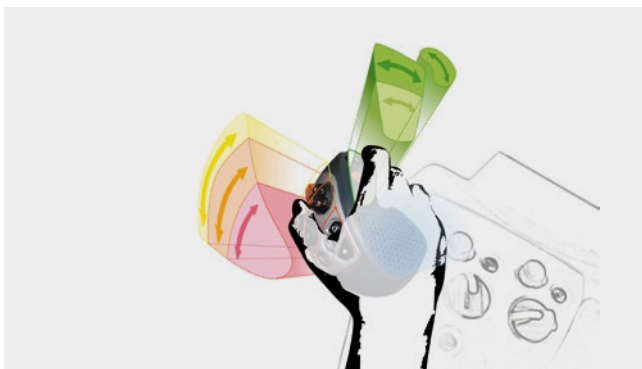

CMOTION multifunction control lever.

The CMOTION is a CLAAS concept which makes using the main functions of the AXION 900 easier and more efficient. Functions are controlled using your thumb and forefingers, allowing your hand to stay in one place most of the time and preventing fatigue. The CMOTION allows sensitive and progressive speed adjustment. The further the driver pushes the CMOTION forwards or backwards, the faster the tractor accelerates or brakes.



Fresh air for full power.

The large intake panels in the hood provide plenty of fresh air for cooling and for the engine air filter. Low flow rates at the intake panels help them to stay clean and permeable at all times.

The radiator assemblies are supported by a robust frame and gas-filled shock absorbers open the radiator panels to two positions for thorough cleaning. Cleaning can therefore be carried out safely and conveniently as required.

Quick access saves time and money.

Daily maintenance work should be as straightforward as possible – because we know from experience that nobody enjoys doing things that are complicated or inconvenient.

- The large, one-piece hood opens at the press of a button, providing access to all the engine maintenance points
- The engine oil can be checked and topped up on the right-hand side of the tractor when the hood is closed
- All daily maintenance tasks can be carried out without tools
- The fuel prefilter is conveniently located by the left-hand cab access ladder
- Large drawer in the left-hand access ladder with space for a standard toolbox
- External battery terminals, e.g. for mobile refueling in the field



The air filter is accessibly located in the cool zone in front of the radiator panels so it can be removed without hindrance. Coarse dirt particles are extracted in the filter housing, further extending the cleaning interval.



External battery terminals are within easy reach by the left-hand cab access ladder.



The engine air filter is in front of the radiator and easy to reach from the ground.

Maintenance Overview		Maintenance	
Next maintenance in 10 hours	10 h	Overview	Information
Next maintenance in 50 hours	38 h	Alarms	Version
Next maintenance in 100 hours	88 h		
Next maintenance in 500 Hours	488 h		
Next maintenance in 1000 hours	988 h		

Maintenance counter in the CEBIS and CIS display.

Specifications.

AXION		960	960 TERRA TRAC	950	940	930	930 TERRA TRAC	920
Engine type and size	L	FPT 8.7	FPT 8.7	FPT 8.7	FPT 8.7	FPT 8.7	FPT 8.7	FPT 8.7
Rated engine speed	rpm	2,000	2,000	2,000	2,000	2,000	2,000	2,000
Rated engine power	hp	440	440	405	380	350	350	320
Max. engine power	hp	445	445	410	385	355	355	325
Advertised PTO HP SAE, OECD-2, PTO rated speed	hp	391	391	357	334	296	296	263
Transmission		CMATIC	CMATIC	CMATIC	CMATIC	CMATIC	CMATIC	CMATIC
Transmission type		CVT	CVT	CVT	CVT	CVT	CVT	CVT
Engine speed at max. power	rpm	1,800	1,800	1,800	1,800	1,800	1,800	1,800
Engine speed at max. torque	rpm	1,400	1,400	1,400	1,400	1,400	1,400	1,400
Cooling system		Visctronic fan	Visctronic fan	Visctronic fan	Visctronic fan	Visctronic fan	Visctronic fan	Visctronic fan
Hydraulic pump flow	gpm	58	58	58	58	58	58	58
Max. flow at couplers – 1 spool/2 spool	gpm	29/53	29/53	29/53	29/53	29/53	29/53	29/53
Max. front lift capacity	lbs	11,023	11,023	11,023	11,023	11,023	11,023	11,023
Max. rear lift capacity	lbs	24,802	24,802	24,802	24,802	24,140	24,140	24,140
Cont. rear lift capacity OECD code 2	lbs	19,400	17,100	19,400	19,400	19,400	17,100	19,400
Fuel tank capacity	gal	170	229	170	170	170	229	170
DEF tank capacity	gal	15	24	15	15	15	24	15

Dimensions and weights

Standard

Height: center of rear axle to cab roof (a)	in	95	95	95	95	95	95	95
Length: front linkage folded, cat. IV rear lower links (b)	in	226	245	226	226	226	245	226
Wheelbase (c)	in	124	116	124	124	124	116	124
Weight	lbs	28,660-30,864	35,714	28,660-30,864	28,660-30,864	27,557-29,762	35,714	27,557-29,762

Bundle offering	Includes
Cold Start	Engine block heater, fuel filter heater, rear window defroster, and heated mirrors (if electric adjust)
Deluxe Cab	Chrome plated exhaust, right side wiper/washer, electric adjust mirrors, wide rear fender extensions, extra monitor mount rail, removable storage box, metal toolbox, semi-active heated leather driver's seat, and leather instructor's seat
Air Brake	Air compressor and two line air brake couplers with single hydraulic line brake coupler
Front Hitch / PTO	5T front 3-point hitch, two mid-mounted valves with front couplers, position control on front hitch, front ISOBUS connection, and front external hitch controls
Work Light Package	All halogen: two additional front and two additional rear roof-mounted lights, and six additional mid-mounted lights
Pro Light Package	All LED: two additional front and two additional rear roof-mounted lights, six additional mid-roof lights, and headlights

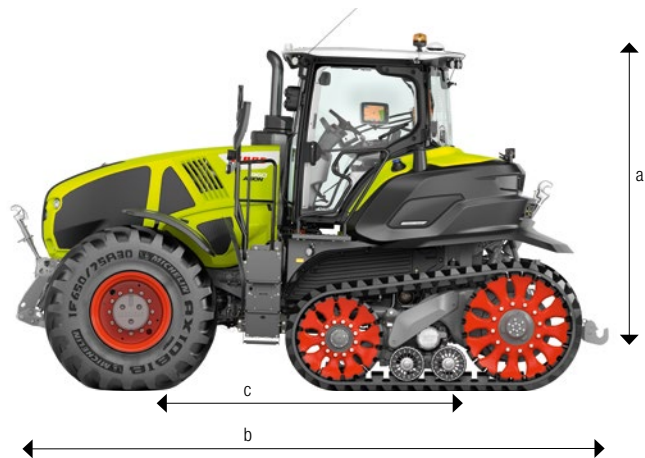
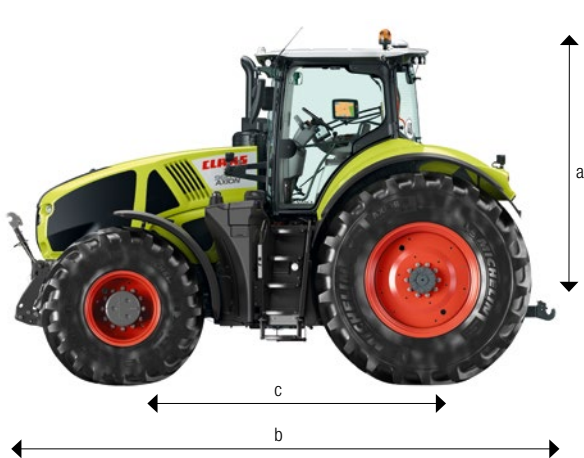

©2024 CLAAS of America Inc. All descriptions and specifications should be considered approximate and may include optional equipment. In certain cases, protective panels have been removed to show detail. To avoid risk of injury, never remove these panels yourself. Please refer to operators manual for instructions. Product and specifications subject to change without notice.

Whatever it takes CLAAS Service + Parts.



Your needs matter.

You can always rely on CLAAS Service & Parts. We'll be there whenever you need us, around the clock if necessary, to provide the perfect solution for your machine and your business. Whatever it takes.

Reliability can be planned.

With our service products, you can increase your machine reliability and minimize your risk of breakdowns with confidence. CLAAS MAXI CARE offers planned reliability for your machine.

Worldwide coverage from Columbus, Regina and Hamm.

The CLAAS of America Parts Logistics Centers in Columbus, Indiana, and Regina, Saskatchewan, provide world-class parts support throughout North America for all CLAAS products. Supported by the CLAAS worldwide spare parts depot in Hamm, Germany, we provide the CLAAS dealer network with reliable, consistent parts availability and industry-leading responsiveness. Your local CLAAS dealer can supply the right parts solution for your business to maximize machine uptime.



CLAAS of America Inc.
8401 S 132nd Street
Omaha, NE 68138
Phone (402) 861-1000
www.claas.com

CL99881069 / 8/2024